

## BX1500

Art. 252956 V01.1 2020-03-10  
© STOBAG AG www.stobag.com

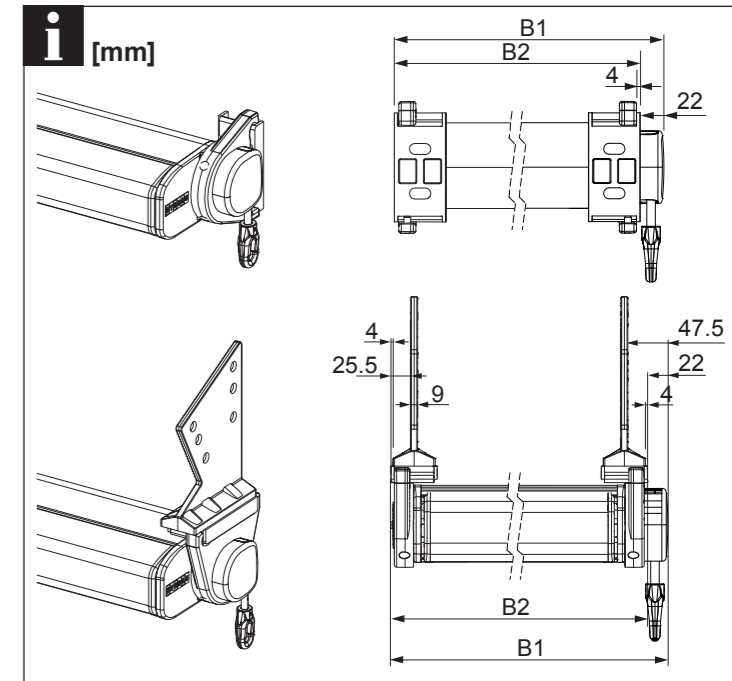

EN 13561:2004+A1:2008

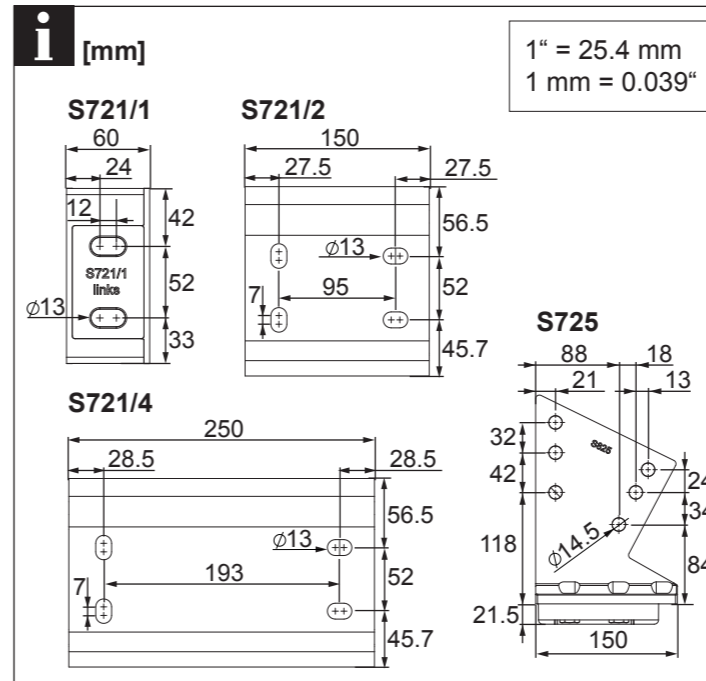
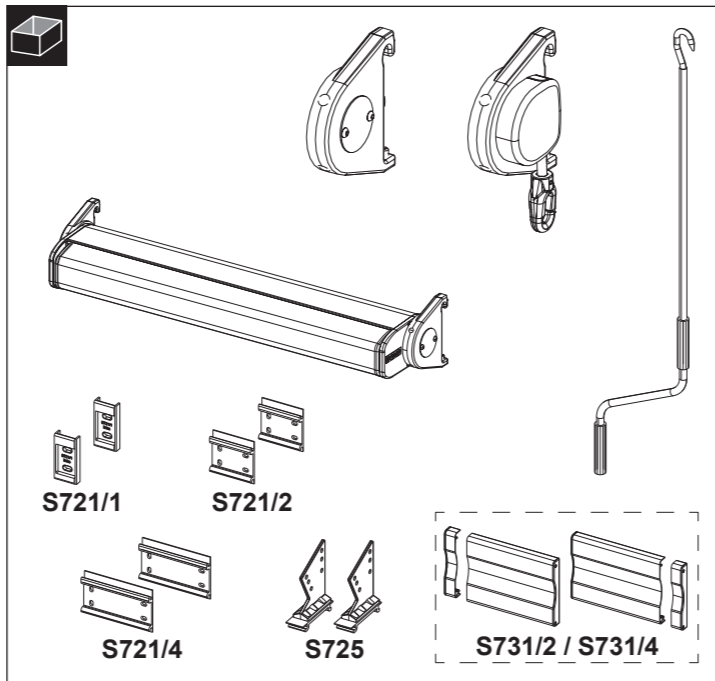

**DE** Installation nur durch geschulte Fachkräfte erlaubt. Sicherheitshinweise in der Bedienungsanleitung unbedingt beachten.

**EN** Installation is only to be carried out by trained specialists. It is extremely important that the safety instructions in the operating manual be followed.

**FR** Seul le personnel spécialisé est autorisé à effectuer l'installation. Il faut impérativement respecter les consignes de sécurité du mode d'emploi.

**ES** Instalación permitida solamente por especialistas con formación. Por favor, tenga en cuenta las indicaciones de seguridad en las instrucciones de uso.

**PT** A instalação só é permitida se for efectuada por pessoal especializado com formação. Observar impreterivelmente as indicações de segurança no manual de instruções.

**IT** È permesso fare seguire l'installazione solo da personale specializzato e istruito a tal fine. Rispettare assolutamente le indicazioni di sicurezza incluse nel manuale d'uso.

**NL** Installatie alleen toegestaan door geschoolde vakkrachten. Veiligheidsinstructies in de gebruiksaanwijzing absoluut in acht nemen.

**DA** Installationen må kun udføres af uddannede fagfolk. Sikkerhedshenvisningerne i betjeningsvejledningen skal altid overholdes.

**SV** Endast utbildade fackmän får utföra installationen. Säkerhetsanvisningarna i bruksanvisningen måste ovillkorligen följas.

**NO** Installasjonen må kun utføres av opplærte fagfolk. Sikkerhetsanvisningene i brukerhåndboken må følges.

**FI** Asennuksen saa tehdä vain koulutettu ammattihenkilökunta. Käyttöohjeiden turvallisuusohje on ehdottomasti huomioitava.

**SL** Nameštitev je dovoljeno izvajati samo usposobljenim strokovnim osebam. Obvezno je treba upoštevati varnostne napotke v navodilih za uporabo.

**CZ** Instalaci smí provádět pouze vyškolení kvalifikovaní odborníci. Bezpodmínečně dodržujte bezpečnostní pokyny uvedené v návodu k obsluze.

**PL** Instalacja dokonywana może być wyłącznie przez przeszkolonych specjalistów. Wskazówki bezpieczeństwa zawarte w instrukcji obsługi muszą być bezwzględnie przestrzegane.

**RU** Монтаж разрешается проводить только обученному персоналу. Следует обязательно выполнять правила техники безопасности, приведенные в руководстве по эксплуатации.

**HU** Beszerelését csak képzett szakemberek végezhetik. A kezelési útmutató biztonsági utalásait mindig figyelembe kell venni.

**JA** インストールは研修を受けた専門員だけが行ってください。取扱説明書内の安全指図書項は必ず遵守してください。

**EL** Η εγκατάσταση επιτρέπεται να διεξάγεται μόνο από καταρτισμένο προσωπικό. Είναι απαραίτητη η τήρηση των οδηγιών ασφαλείας που περιέχονται στις οδηγίες χρήσης.

**TR** Kurulum sadece eğitimli uzman personel tarafından yapılmalıdır. Kullanım kılavuzundaki güvenlik uyarılarını mutlaka dikkatle dilmelidir.

**HR** Instalaciju smije izvoditi samo stručnoobučeno osoblje. Obvezno je pridržavati se sigurnosnih napomena iz uputa za uporabu.

